

# Wobbly Log Bridge

Manufacturers Information | A-NAT-2264

## Installation

### Footing quantities and depths

From ground level

Item	Qty	Hole Diameter	Hole Depth
Stepper	2	400mm	500mm
Post	4	400mm	850mm

### Note:

This product is designed for 300mm softfall. Check the proposed on site softfall depth. If it is not 300mm please adjust depths of post holes accordingly, to achieve correct overall subsurface depth. This will maintain correct height of equipment above undersurface level.

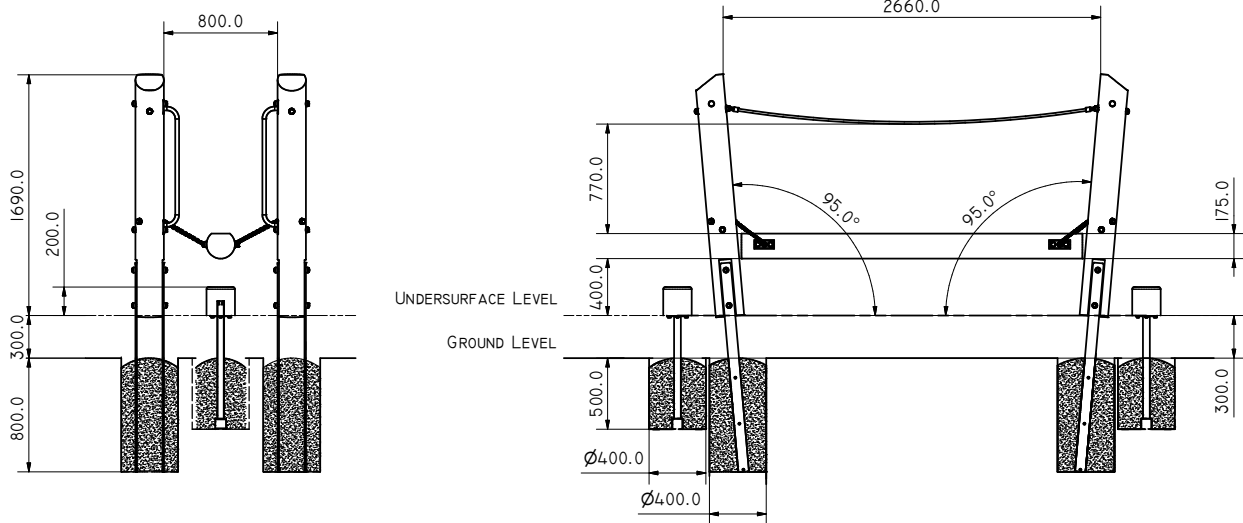

## Inspection Notes

All inspections and maintenance to be carried out by competent people with the appropriate knowledge, experience and authority.

### Inspection Frequencies

These are a guide only - local risk factors such as heavy usage, nearness to coast, and vandalism patterns need to be taken into account.

#### Routine Visual Inspection - Daily

Check for breakages, loose fittings and debris. Where safety issues are identified, quarantine until repaired.

#### Operational Inspection - Quarterly

RVI plus:-  
Check for wear in moving parts e.g. bearings, chains and links  
Check security fixings.

#### Comprehensive Inspection - Annually

OI plus :-  
Check for structural rigidity and degradation e.g. corrosion, decay etc. Where possible, remove undersurfacing to examine condition of supports and footings.

## Maintenance - Annual

Regular inspection for signs of insect or fungal attack and, where evident, cleaning and treating as appropriate.

Apply 2 coats of water-based decking oil every 6 months

Cracks will open and close with the weather, particularly dry heat or prolonged wet. Where significant (i.e. >5mm) they can usually be caulked with an exterior grade silicon (available in colours to suit). Where splinters form, they can be removed and sanded smooth before re-coating.

In areas of high exposure to sun, wind and rain more frequent treatments may be necessary.

Note: Ensure all replacement parts conform with manufacturers original specifications

Note: In heavy use environment, more frequent inspection regime recommended

Note: Quarantine equipment during installation, inspection & maintenance